





# GENUINE FRONT MUD FLAP

## INSTALLATION AND USER'S INSTRUCTIONS

Thank you for purchasing a genuine Mazda accessory.  
Before removal and installation, be sure to thoroughly read these instructions.  
Please read the contents of this booklet in order to properly install and use the front mud flap. Your safety depends on it.  
Keep these instructions with your vehicle records for future reference.

### **WARNING**

- There are several  **WARNING** and  **CAUTION** sections in this booklet concerning safety when installing or removing the front mud flap. Always read and follow them in order to prevent injuries, accidents, and possible damage to the vehicle.
  -  **WARNING:** Indicates a situation in which serious injury or death could result if the warning is ignored.
  -  **CAUTION:** Indicates a situation in which bodily injury or damage to the vehicle could result if the caution is ignored.
- For areas indicating the tightening torque in this instruction manual, tighten to the specified torque using a torque wrench. For areas in which the tightening torque is indicated inside parentheses ( ), the tightening torque is indicated as a reference value, however tightening using a torque wrench is not necessary.
- Do not modify the front mud flap.
- Do not install the front mud flap. In any way other than described in the following instructions.
- If in any doubt, please ask your Mazda dealer to install the accessory in order to prevent errors in installation.
- If you have any questions about the use of the accessory, ask your Mazda dealer for proper advice before using it.
- Mazda and its suppliers are not responsible for injuries, accidents, and damage to persons and property that arise from the failure of the dealer or installer to follow these instructions.
- To ensure safety and reliability of the work, installation, removal and disposal work must be carried out by an Authorized Mazda Dealership.
- Be careful not to lose removed parts and be sure that they are kept free from scratches, grease or other dirt.

**PART NAME: FRONT MUD FLAP**  
**PART NUMBER: BHN1 V3 450**  
**VEHICLE: MAZDA3**

### **NOTE**

#### **To the dealer**

- Please turn over these instructions to the customer after installation.

#### **To the customer**



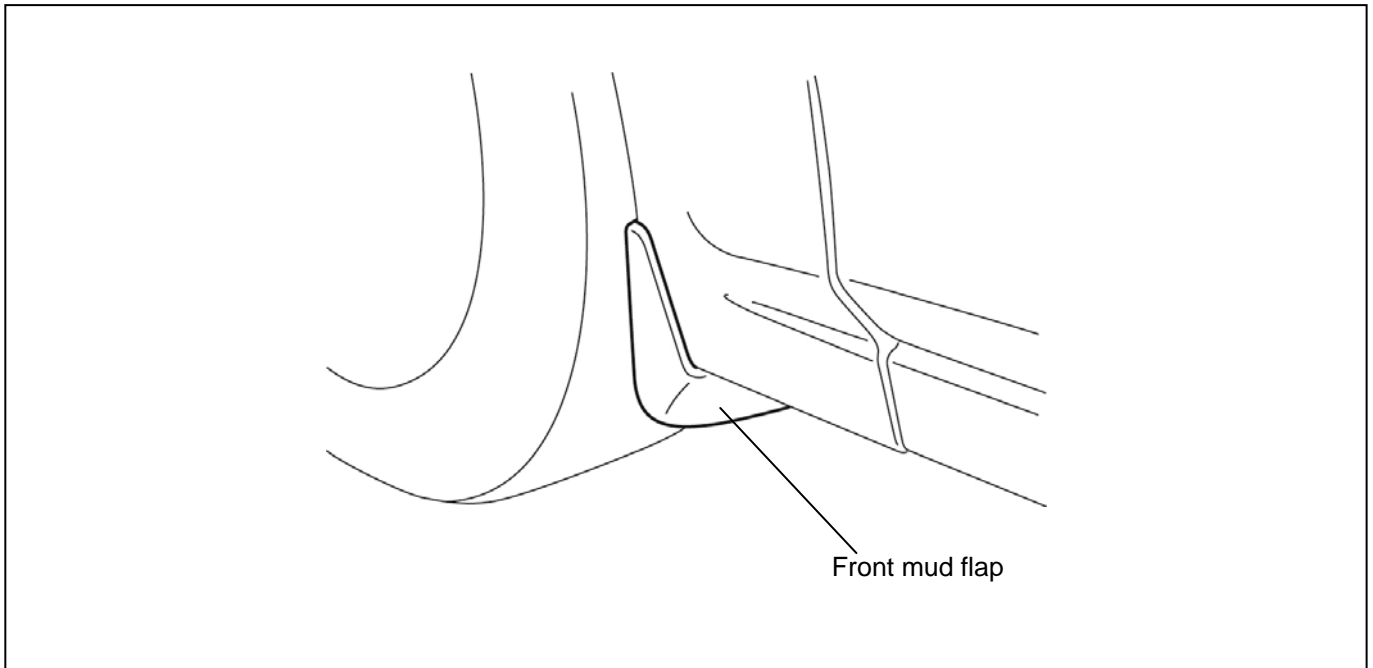

- Keep these instructions after installation. The instructions may be necessary for installing other optional parts or removal of this accessory.
- Should the vehicle or this accessory be resold, always leave these instructions with it for the next owner.

# 1. INSTALLATION VIEW



# 2. PARTS

- Before installation, verify that the kit includes all the following parts and that they are free of dirt, scratches, or damage.

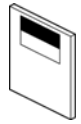
Part	Part name	Qty	Part	Part name	Qty	Part	Part name	Qty
	Front mud flap RH/LH	1ea.		Tapping screw	4		Clip nut	4
	Fastener	2		Installation Instructions	1			

# 3. BEFORE INSTALLATION

## ■ REQUIRED TOOLS

- ☆ Flathead screwdriver
- ☆ Fastener remover
- ☆ Torque wrench
- ☆ Soft, clean cloth

### ⚠ WARNING

Park the vehicle on a flat, level surface, set the selector lever to P (AT vehicles) or the shift lever to 1st or R (MT vehicles), apply the parking brake and block the wheels so that the vehicle does not move during installation.

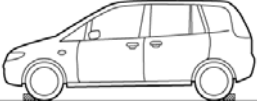

### ⚠ CAUTION

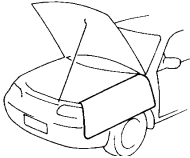
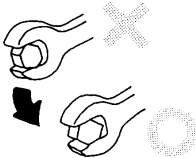
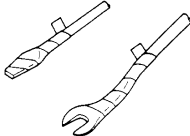
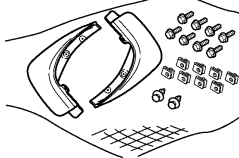
<p>Be sure to cover the vehicle body with protectors or mats to prevent stains, scratches and damage when removing/installing the vehicle parts</p>	<p>Using improper tools may cause damage and or broken parts. Use the correct tool for the job.</p>	<p>Wrap protective tape around screwdrivers and fastener remover tools to prevent scratching the vehicle.</p>	<p>Put the removed parts and the parts in the kit on a protective sheet to prevent scratches.</p>
			

### Advice

Refer to the Workshop Manual for removal and installation of vehicle parts. Not following the procedures for removal/installation in the Workshop Manual could result in an accident or vehicle malfunction.



## 4. MUD FLAP (FRONT) INSTALLATION

- The figures show the left side, however, the procedure for the right side is the same.

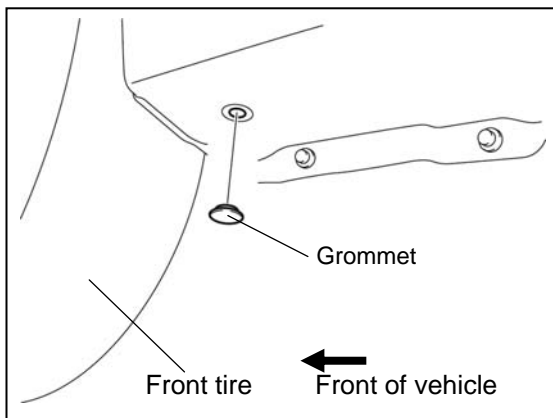

1. Remove the grommets (2) shown in the figure.

- The removed grommets are not reused.

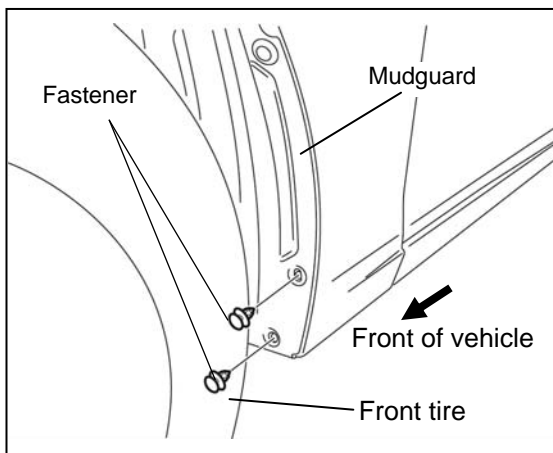

2. Remove the fasteners (2) as shown in the figure.

- The removed fasteners are not reused.

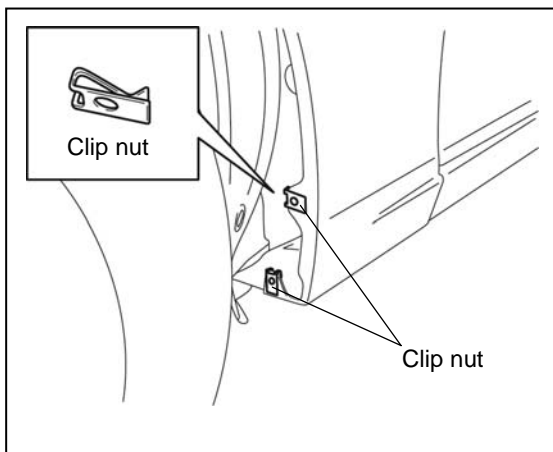

3. Pull back the mudguard, align the clip nuts (2) with the installation holes in the front fender, and install.

- When installing the clip nuts, ensure that the flat face of the clip nut is facing towards the front of the vehicle. If installed incorrectly, mud flap will not install properly and may come off.

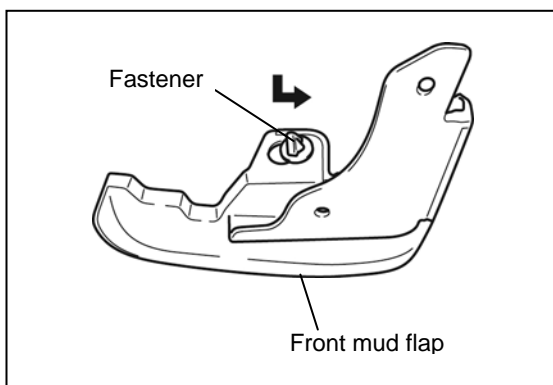

4. Install the fastener (1) to the mud flap.

- Verify the installation that the fastener is installed the mud flap as shown in the figure.

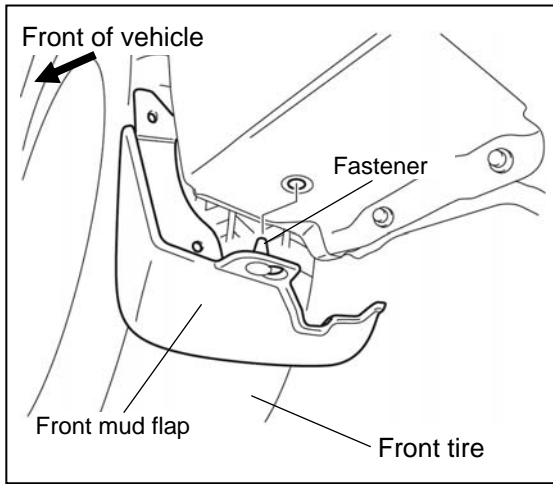

5. Install the fastener to the installation hole of the grommet removed in Procedure 1, and verify click sound.

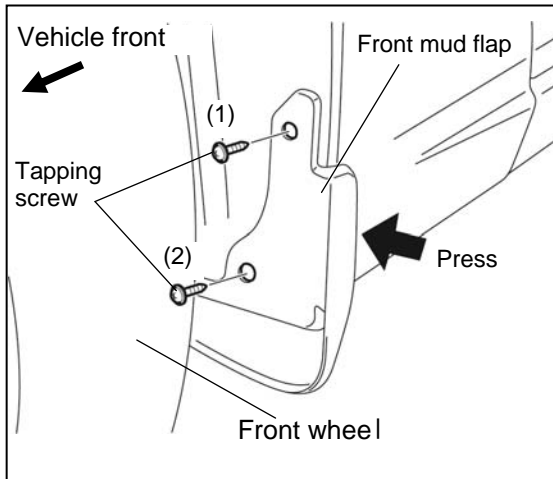

6. While pressing the front mud flap against the body, install the tapping screws in an order of (1) to (2) as shown in the figure.

**Bolt tightening torque (0.8–1.2 N·m)**

**ADVICE**

- Make sure there is no gap between the mud flap (front) and front fender when installing.

## 5. INSPECTION ITEMS AFTER INSTALLATION

1. Make sure that there are no gaps.

- If there is gap, loosen the tapping screws, then retighten them while pressing the front mud flap against the body.

2. Inspect the installation of the installed tapping screws.

## 6. TO THE CUSTOMER

Please pay attention to the following with regard to handling (maintenance) of the mud flap (front).

- If the hard plastic parts come into contact with gasoline, oil, refrigerant, or battery fluid, it could cause discoloration, staining or damage. Use a soft, clean cloth to wipe such fluids off immediately.
- Depending on the type of high pressure car washer used, the water for washing may be high temperature and/or under high pressure. Be careful when using pressurized water from a car washer nozzle. If the nozzle is too close or water pressure is applied for long periods, it may cause deformation or damage to the hard plastic parts.
- Do not use electric or air tools to apply wax or compound (polishing powder). Otherwise, friction heat will be generated causing deformation or damage to the hard plastic parts.
- If the vehicle height is lowered due to the vehicle being at maximum passenger or cargo capacity, decrease the vehicle speed when parking on a road shoulder or entering/leaving a road shoulder or bump. Otherwise, the mud flaps (front) could be damaged.

Date _____, _____, _____				
VIN _____				
Approved		Checked		Person in charge

<b>INSTALLATION INSPECTION SHEET</b>	<b>MAZDA3</b>	<b>Front mud flap</b>
		BHN1 V3 450

Perform the following inspections

**Inspection items after installation**

Check

- Verify the fitting between the vehicle part and the installed part, and inspect for damage or dirt.

The term of validity for this sheet: 3 year